

COMPANY PROFILE

# 正恒动力

Chengdu Zheng Heng Auto Parts Co.,Ltd.  
Nov. 2018.

# 目录

## CONTENTS

---

01. 公司与团队  
Company and Team

02. 产品与客户  
Product & Partner

03. 研发能力  
R & D Capability

04. 生产能力  
Production Capability

PART 01

# 公司与团队

Company and Team

---



# 公司简介

Company Profile



**坐标：中国·成都 CHENGDU. CHINA**

成都正恒动力股份有限公司专注于汽车发动机缸体及相关汽车零部件的研发和生产，提供设计、模具、铸造、机加工的一站式服务。旗下拥有四家工厂，铸造工厂成立于1977年，历经多年的发展，正恒股份已成为国内知名的发动机缸体、轴承盖、油泵体、变速箱壳体、电机压铸壳体生产基地。

Chengdu Zhengheng Auto Parts Co.,Ltd. specializes in cylinder block and related parts R&D and production. We provide one-stop solution from products design, mold, casting and machining. Founded in 1977, our company has developed into a well-known supplier of cylinder blocks, bearing caps, oil pump bodies, gearbox housings and motor casings.

# 超过40年的发展历程

More than 40 years experience

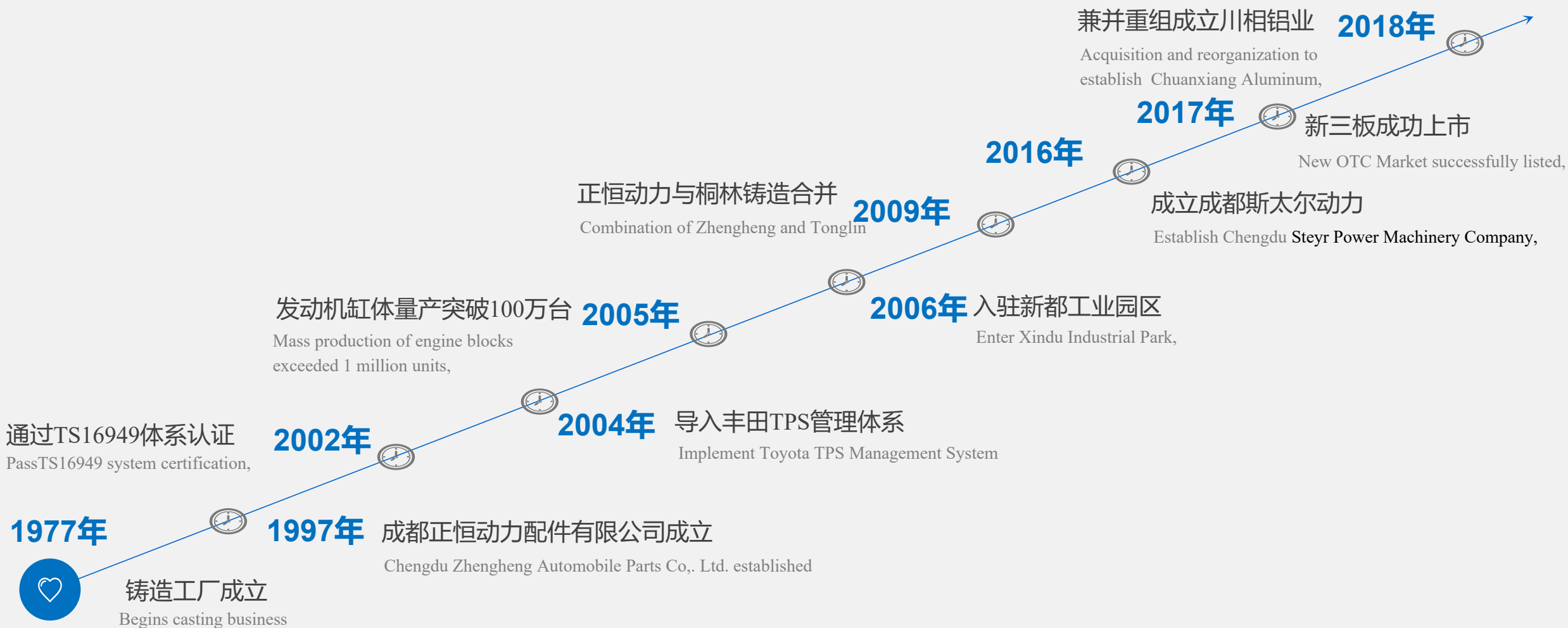

# 组织架构

Organization



## CEO 刘帆

Mr. Liu Fan, one of the founders is currently the CEO of the company

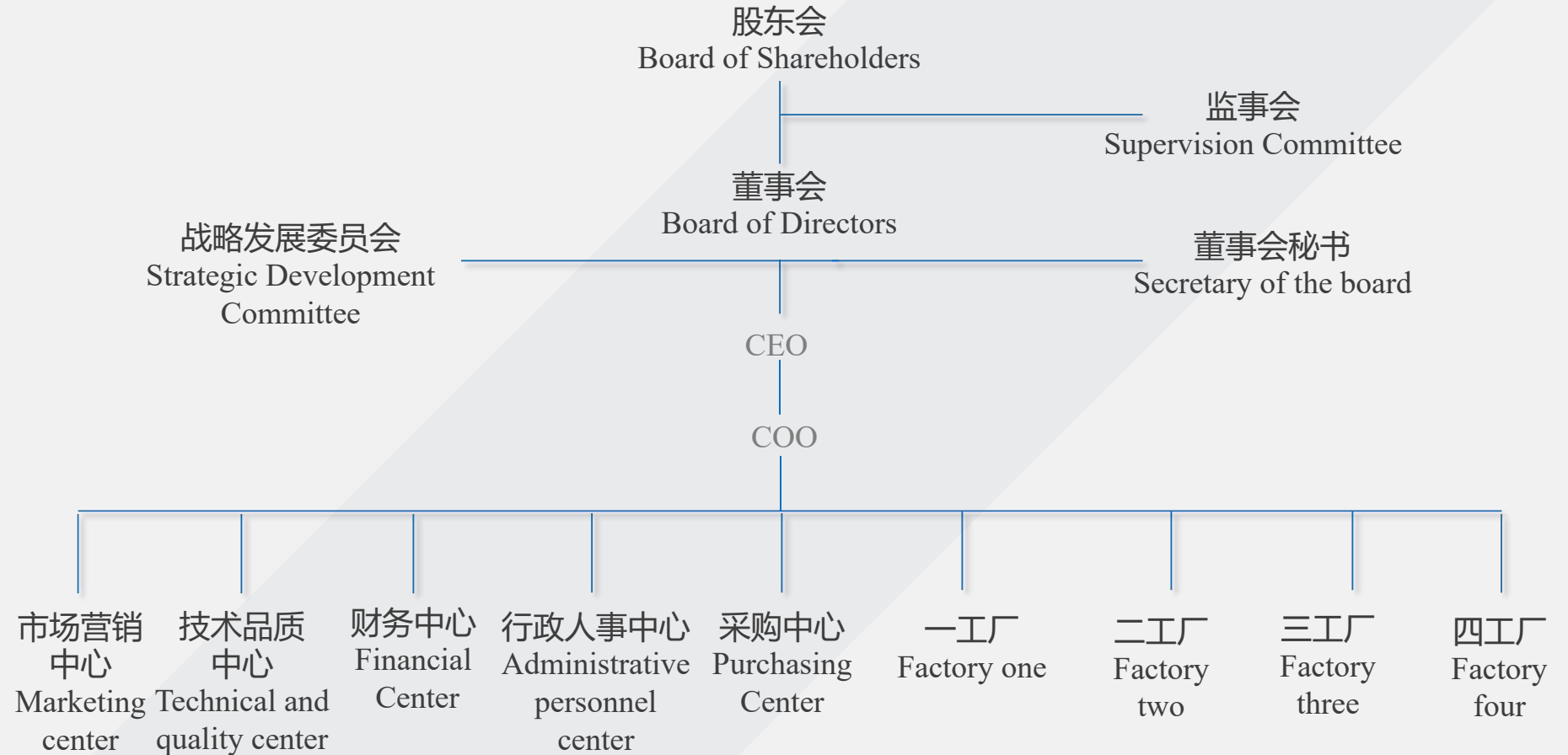



# 管理体系

Management system



- ◆ 2005年，推行丰田生产管理体系（TPS）
- ◆ 2006年，通过 GM-QSB 审核
- ◆ 2015年，通过GE公司EHS审核
- ◆ 2016年，推行长安QCA管理体系
- ◆ 2017年，建立并实施ZHQMS管理体系
  
- ◆ In 2005, implement Toyota Production Management System (TPS)
- ◆ In 2006, passed the GM-QSB audit
- ◆ In 2015, passed the EHS audit of GE
- ◆ In 2016, implementation of Changan QCA management system
- ◆ In 2017, establish and implement ZHQMS management system

# 资质与专利

Qualifications and patents



**IATF 16949质量体系认证**  
IATF 16949 Quality System Certification



## 截止2018年成功申请发明专利及实用新型专利142项

By the end of 2018, we have successfully applied for 142 invention patents and utility model patents



**ISO14001环境管理体系认证**  
ISO14001 Environmental Management System Certification



**OHSAS18001安全管理体系认证**  
OHSAS18001 Safety Management System Certification



# 公司荣誉

Honor



## 客户激励

Customer Award

## 行业认可

Industry recognition

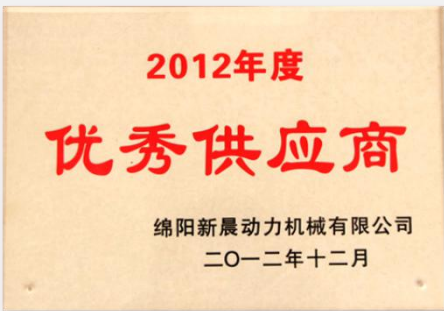
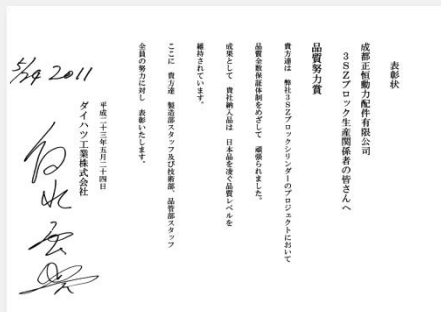

PART 02

# 产品与客户

Product & Partner

---

# 主要产品及应用领域

Main products and application areas



汽车  
Automobile



工程机械  
Engineering Machinery



发电设备  
Generator



船舶  
Ship



航空  
Aviation



轨道交通  
Rail traffic

## 正恒产品 Products

铸铁件  
Iron Casting

铸铝件  
Aluminum Casting

机加工  
Machining

发动机缸体  
Cylinder block 50%

壳体  
Housing 5%

轴承盖  
Main bearing cap 10%

底盘件  
Chassis parts 20%

缸盖  
Cylinder head 5%

其他  
Others 10%



# 铸铁发动机缸体

Cast Iron Cylinder Block

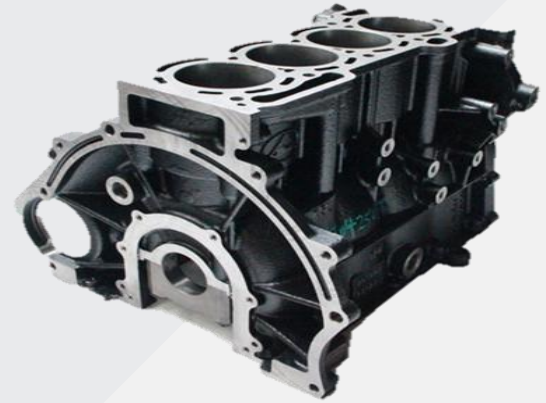
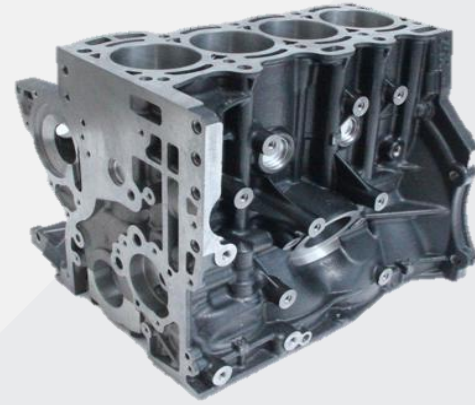
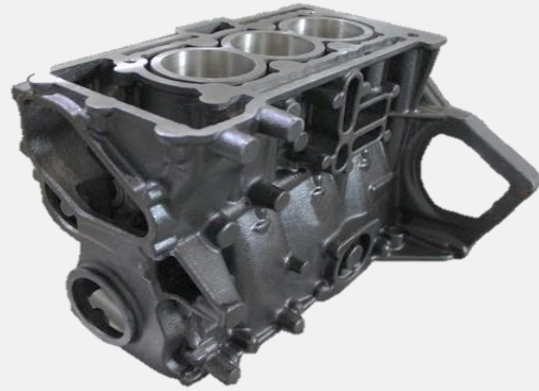
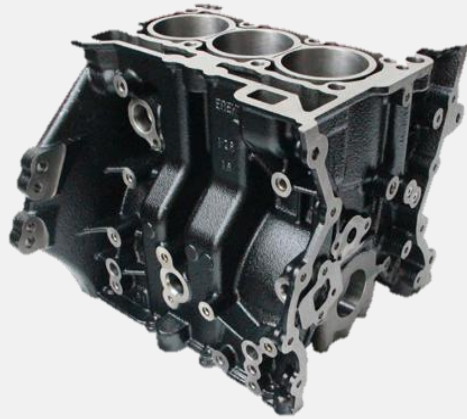

累计设计生产超过100种铸铁发动机缸体  
铸造和机加工缸体总数超过10,000,000件

Over 100 kinds of cylinder blocks been designed and produced

The total number of cylinder blocks casted and machined have exceeds 10 million pcs



# 铸铝发动机缸体

Cast Aluminum Engine Cylinder Block

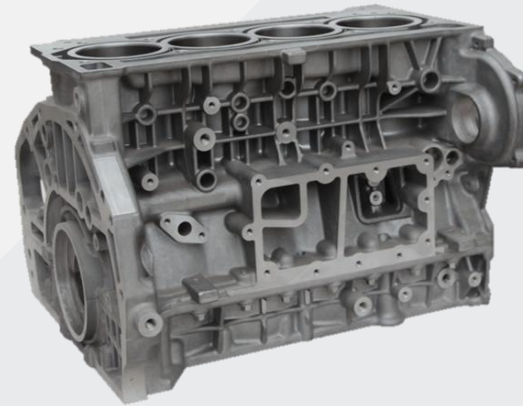
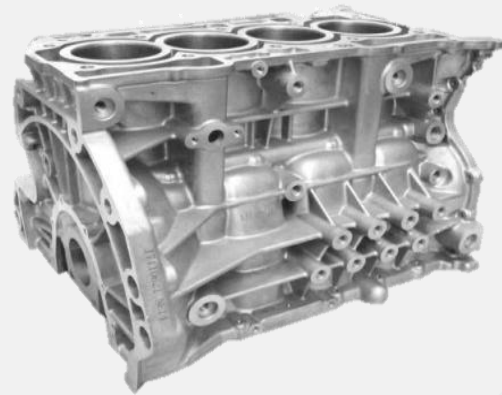

累计设计生产超过20种铸铝发动机缸体

More than 20 kinds of aluminium cylinder blocks been designed and produced

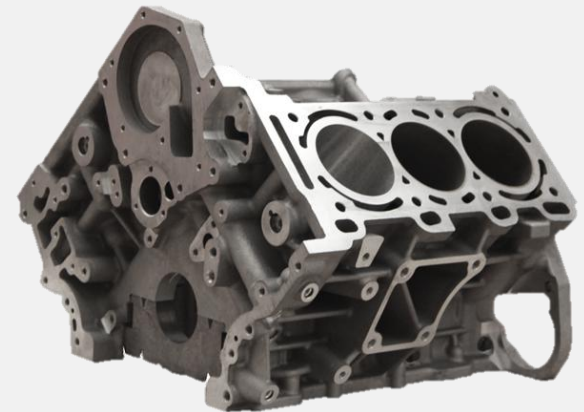
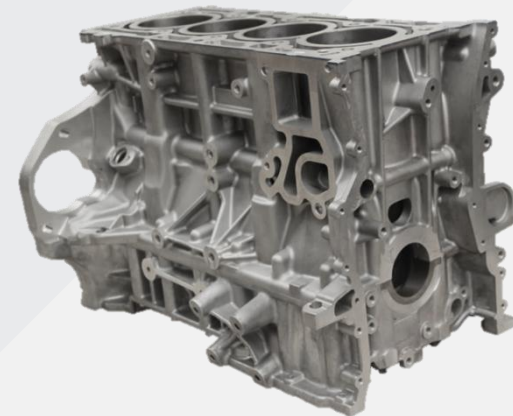
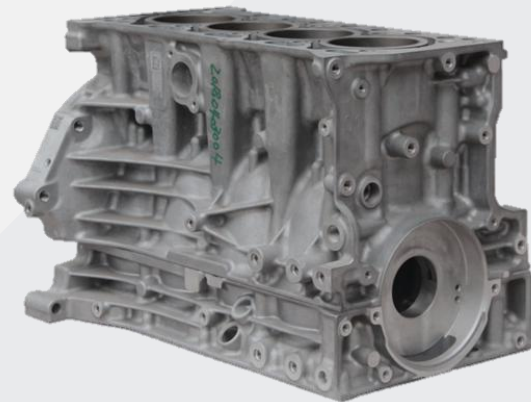
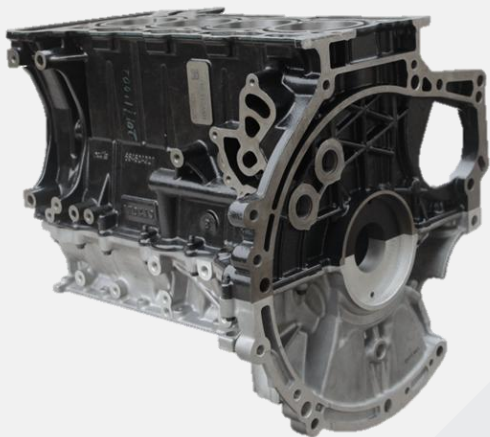



# 小型铸件及其他

Small castings and others



## 壳体 Housing

已开发生产多种型号的汽车及油气零件相关壳体,如: 变速箱壳体、链轮室盖、发动机罩壳、发电机壳体、油气零件壳体等

Various types of housings related to automobile and O & G have been developed and produced, such as gearbox housing, sprocket chamber cover, engine cover, generator housing, thrust chamber housing.



## 底盘件 Chassis parts

两条自动造型线 (DISA、FBO) 生产各类底盘铸件, 如油泵体、反作用支撑、压盘、转向节、卡钳、轮毂等产品

Two automatic molding lines (DISA, FBO) can produce various chassis parts, such as oil pump, reaction support, steering knuckle, calipers, hub.



## 主轴承盖 Main bearing cap

已为汽、柴油发动机厂提供优质主轴承盖超过1000万支

Over 1 million main bearing caps of high quality have been supplied to gasoline and diesel engines manufactures.



## 其他 Others

为各行业定制生产各类精密铸铁、铸铝零件

We provide customized production of precision cast iron and cast aluminium parts for various industries





# 客户分布

## Customer distribution

与国内多家知名汽车主机厂、发动机工厂有着长期密切合作。产品先后出口美国、德国、日本、瑞士、澳大利亚等国家

We have established long-term close cooperation with many well-known OEM and engine factories in China. Our products have been exported to the United States, Germany, Malaysia, Japan, Switzerl, Australia and other countries.

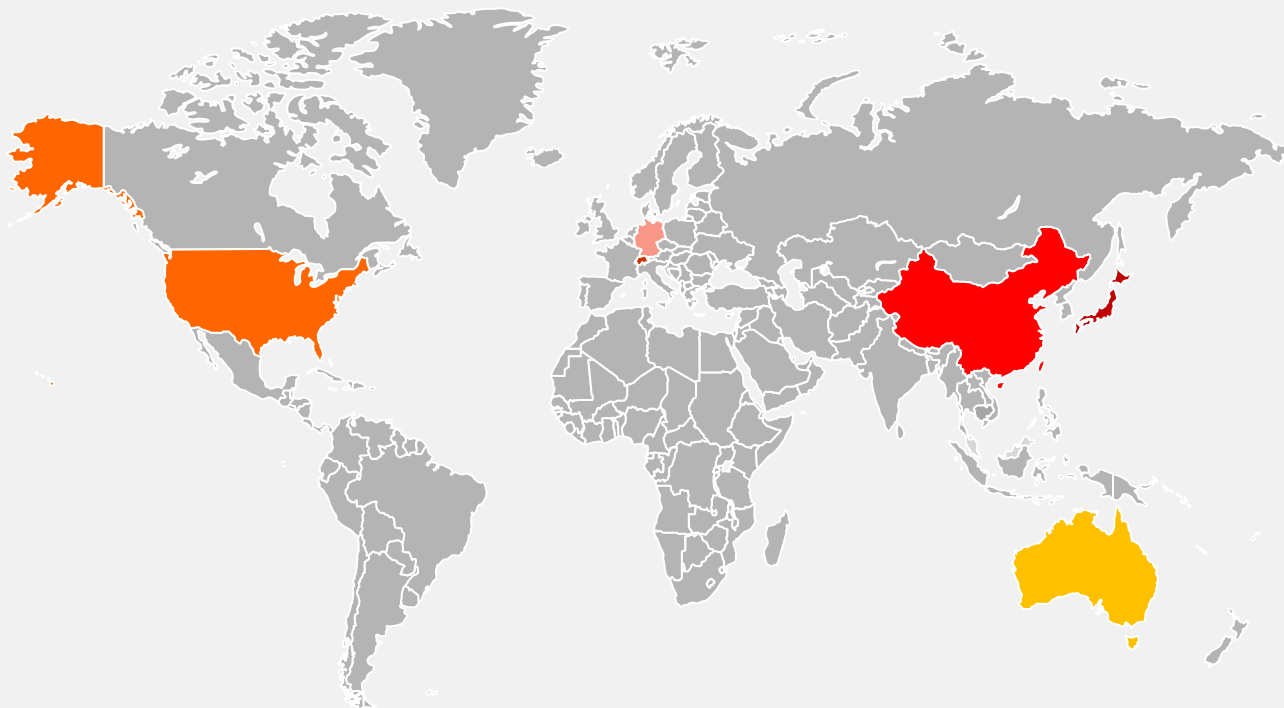

- 中国.CHINA
- 美国.USA
- 德国.GERMANY
- 澳大利亚.AUSTRALIA
- 瑞士.SWITZERLAND
- 日本.JAPAN

## 海外/合资品牌 Overseas / joint venture brands

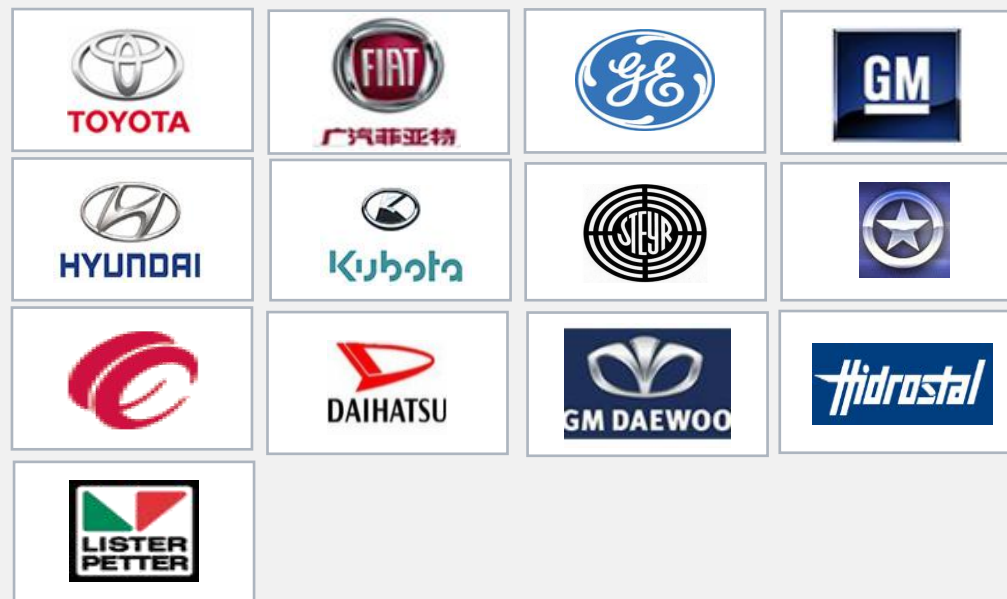

## 国内自主品牌 Domestic independent brand



PART 03

# 研发能力

R & D capability

---

# 研发团队

R & D team



## 拥有强大的技术开发团队：

工程技术人员212余人  
高级工程师12人  
工程师54人  
日本、德国、奥地利5名驻厂指导专家

## Excellent R&D team

A technical team of 212 engineers including 12 senior engineers and 54 engineers. Long-term guidance of experts from Japan, Germany and Austria





# 铸造研发实力

Casting R & D capability



快速样件开发周期: **25天**

Leadtime of rapid prototyping sample development: 25 days

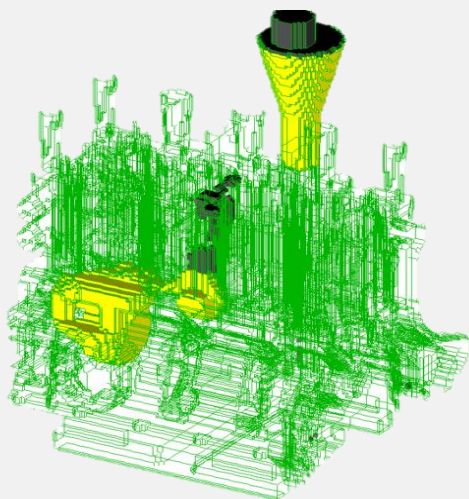

模流分析

Mold flow analysis

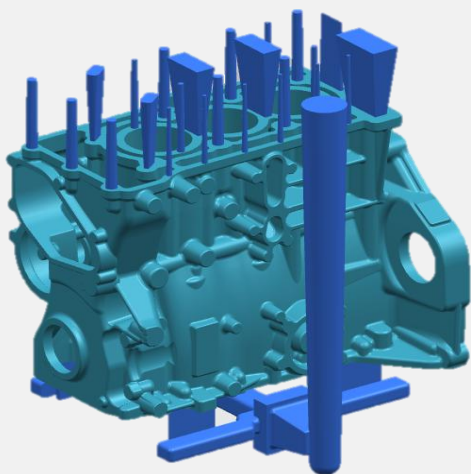

3D设计

3D scheme

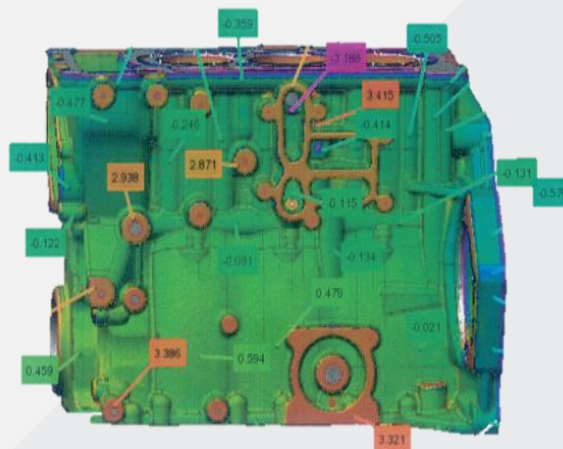

3D扫描

3D scan

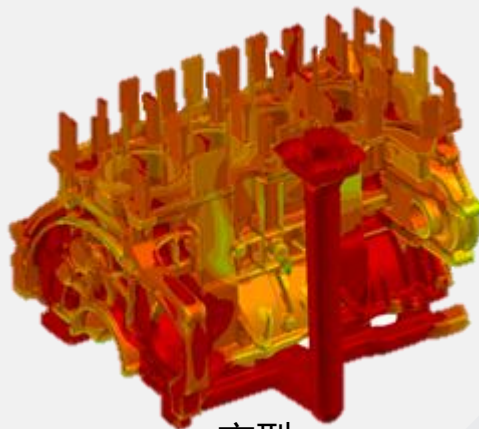

充型

Mold filling

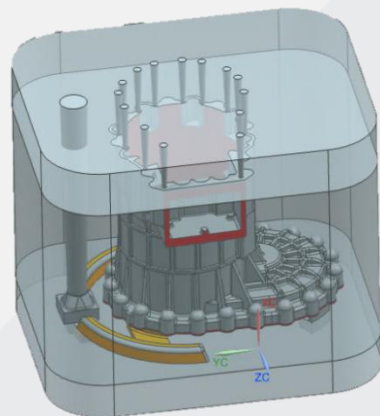

初始工艺方案

Initial process plan

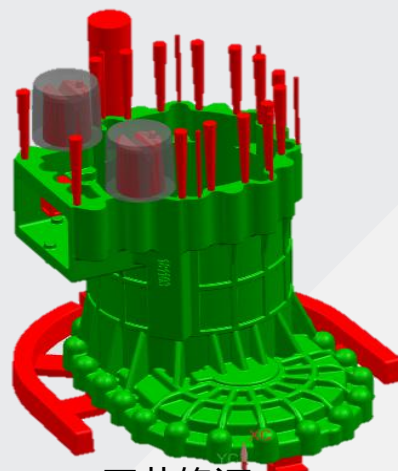

工艺修订

Process revision

掌握先进的三维软件PRO/E、UG、CARTIA、CAE设计技术，PROCAST凝固模流分析、3D打印技术，专业的新品试制线，快速响应客户需求，高效提交样件。

We can rapidly react to customers' request and deliver samples efficiently with advanced three-dimensional design technique like PRO/E, UG, CARTIA, CAE, PROCAST solidification flow analysis, 3D printing and professional new parts trial production line.

# 机加工研发实力

Machining R&D capacity



## 通过自主研发和创新，现在拥有：

工装专机自制能力

强大的缸体开发数据库

缸孔螺旋滑珩、模拟缸盖辅助加工、

一体式缸体加工、曲轴孔线镗工艺等先进加工技术

## TECHNICAL STRENGTH

- Helical slide honing technology
- Simulated cylinder head assisted machining
- Integrated cylinder processing
- Crankshaft hole line boring
- Tooling machine self-made ability
- Establish cylinder block R&D database

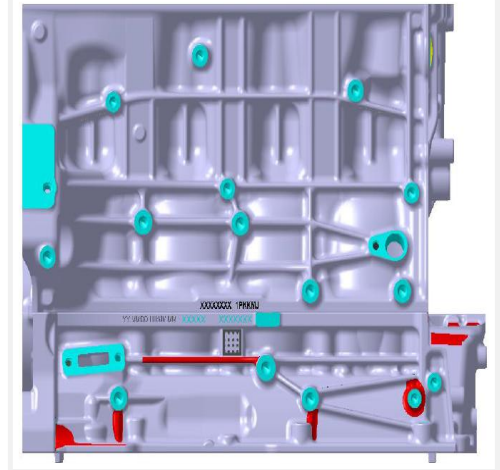
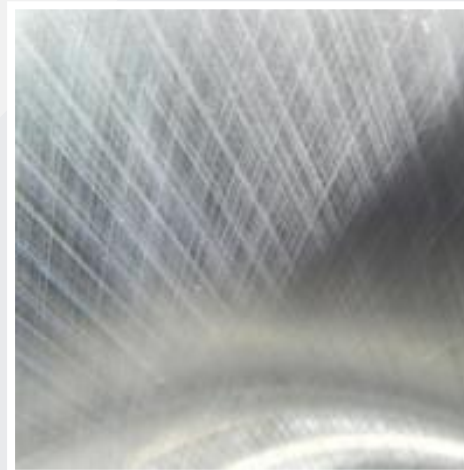
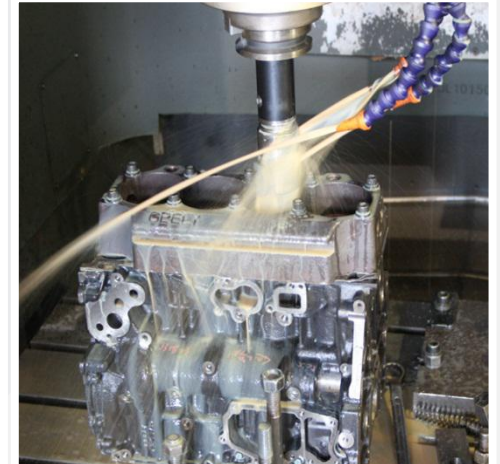
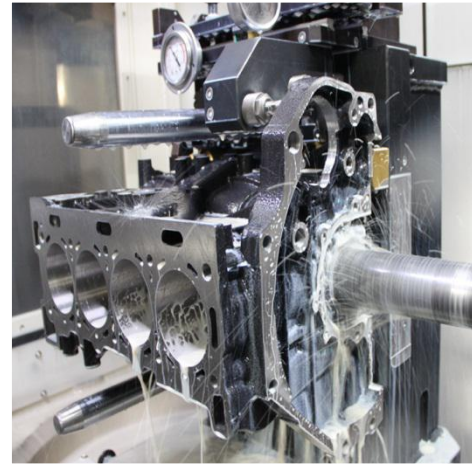



# 行业领先装备

R&D equipment

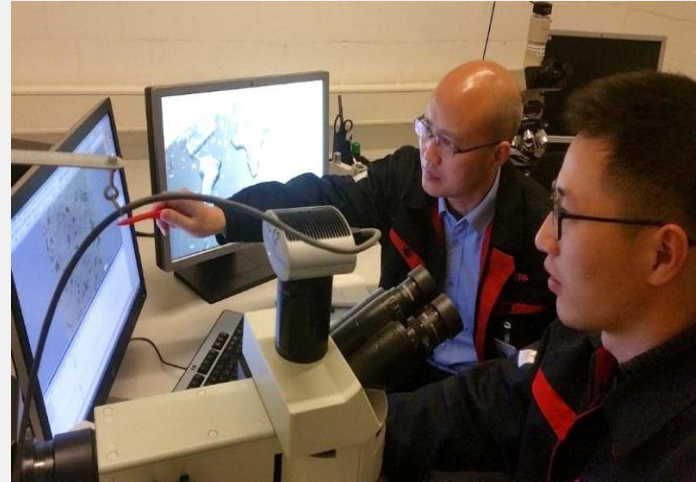
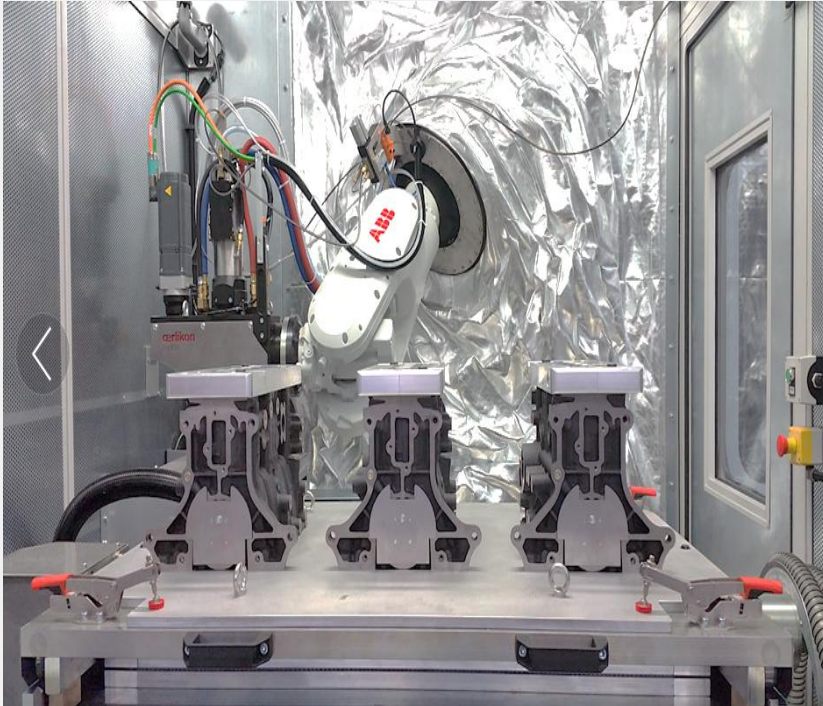

Zhengheng is the first company in China to introduce the plasma spraying technology and equipment for cylinder bore.

**中国首家缸孔等离子喷涂技术中心**

正恒动力是中国首家引进发动机缸孔等离子喷涂技术及设备的公司!

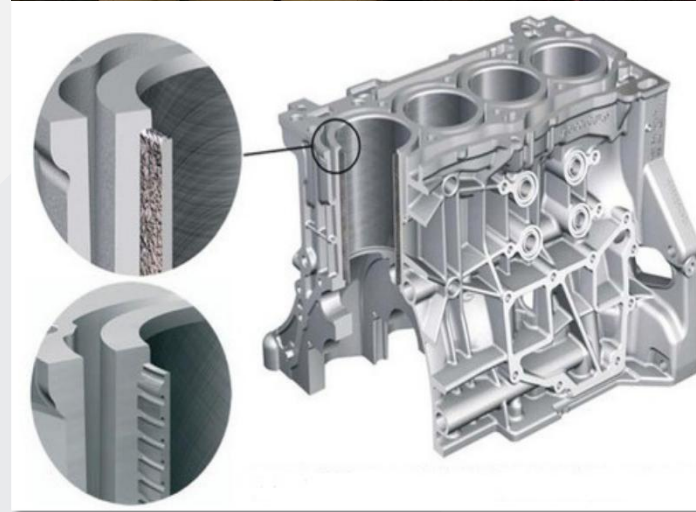



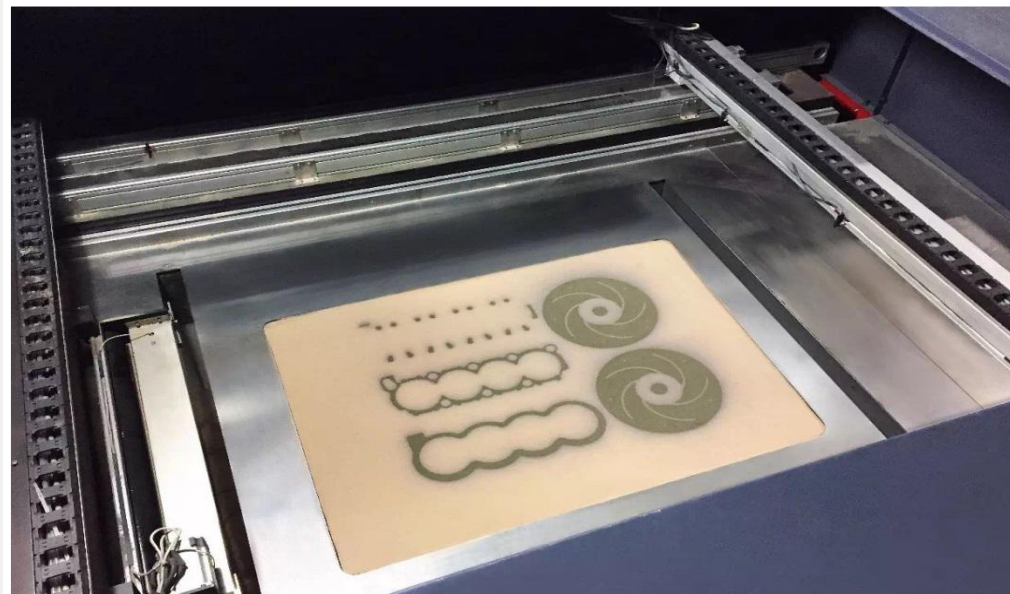

## 3D打印中心

### 3D printing center

- ◆ 设计灵活, 节约成本, 降低制造难度
- ◆ 缩短产品开发周期

## 智制中心

### Intelligent manufacturing center

- ◆ 生产线实时监控、数字化管理度
- ◆ 高效率、高精度、智能化

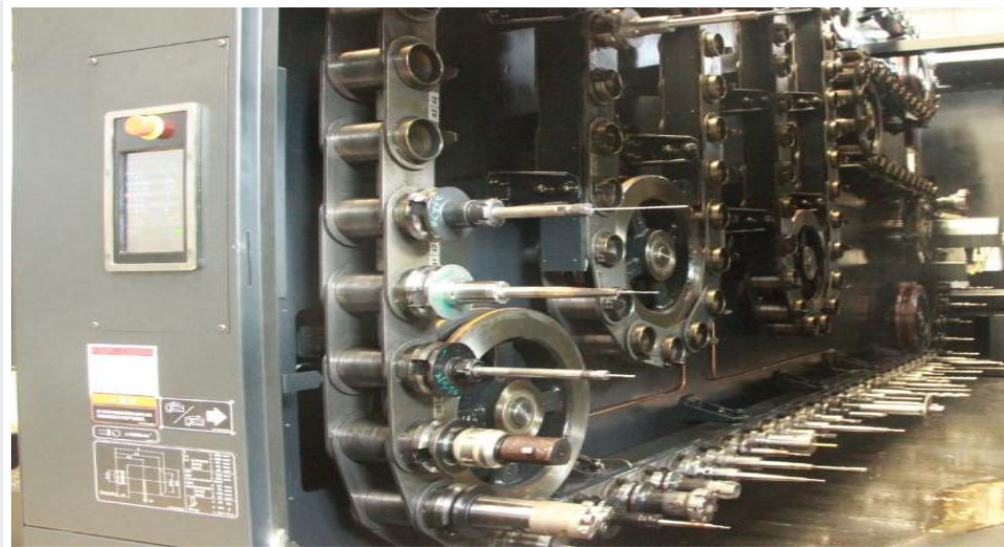

# 研发能力提升

Upgrade R&D capability



与四川大学、昆明理工大学等国内知名高校合作，创建**铸造研究院、热喷涂研究院、智能制造研究院**等，提升企业技术水平，助力正恒持续发展！

Cooperate with Sichuan University and Kunming University of Science and Technology to establish casting research institute and thermal spraying research institute to enhance our technical level and realize our sustainable development target!



PART 04

# 生产能力

Production capacity

---



# 铸造生产车间

Foundry workshop



- 8万吨/年，发动机缸体铸件及小型铸件
- 7条铸造生产线
- 灰铁、球墨铸铁和蠕墨铸铁铸件生产能力
- 热法再生砂处理系统，实现铸造砂再生利用

- 80,000 tons/year, including cylinder blocks and small castings
- 7 casting production lines
- Gray iron castings, ductile iron castings and vermicular cast iron castings ;
- Thermally reclaimed sand treating system realize the sand recycling



# 压铸生产车间

Die casting workshop



- 200吨——2500吨系列压铸机共10台
- 年产4000吨以上压铸产品
- 自有原料供应从源头保证产品质量

- 10 sets die casting equipment range from 200 to 2500 tons;
- Annual output of over 4,000 tons
- Self-owned raw material supply to guarantee products quality from the source



# 机加工生产车间

Machining workshop



正恒股份  
ZHENG HENG



- 15条量产加工生产线, 2个开发试制中心
- 具备年产 80 万件气缸体及 200 万件其它产品加工产能

- 15 mass production lines, 1 development center
- Annual production capacity of 800,000 cylinder blocks and 2 million other products processing capacity



# 智能制造

Intelligent manufacturing



## MDC系统 MDC system

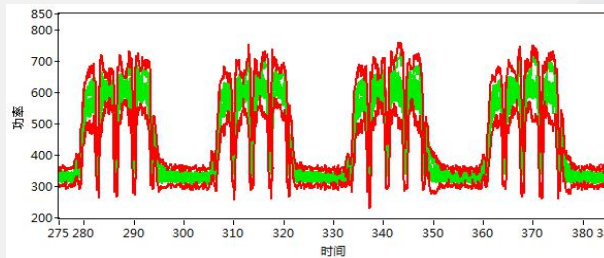
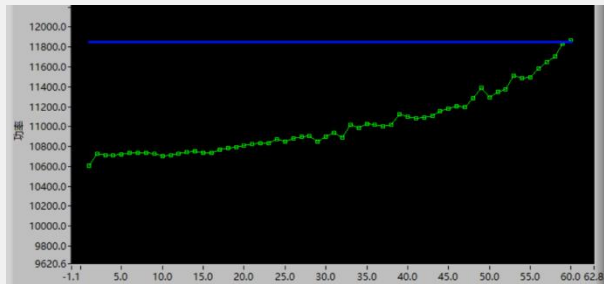
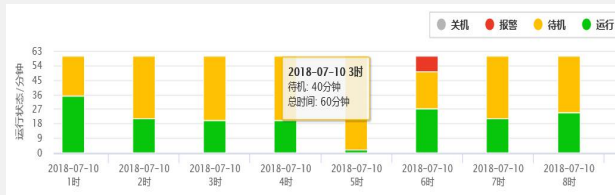

引进科学的天机算MDC系统,对加工中心机床的状态、刀具的监控和异常进行管控。实现加工车间透明可控的管理。

采用机器人清洗机、工位机器人等智能装备,做到生产智能化、数据信息化。

We introduce advanced MDC system to control the status of machining center, the tools and abnormalities to realize the transparency and controllability management of processing workshop. Intelligent equipment such as robot cleaning machines and station robots are used to achieve intelligent production and data informationization.



# 铸造检测能力

Inspection capability



完善的实验室检测、试验能力 Perfect inspection device, excellent inspection ability



金相显微镜  
Metallographic microscope



3D扫描仪  
3D scanner



工业内窥镜  
Industrial endoscope



三坐标仪  
CMM



光谱分析仪  
Spectrum analyzer

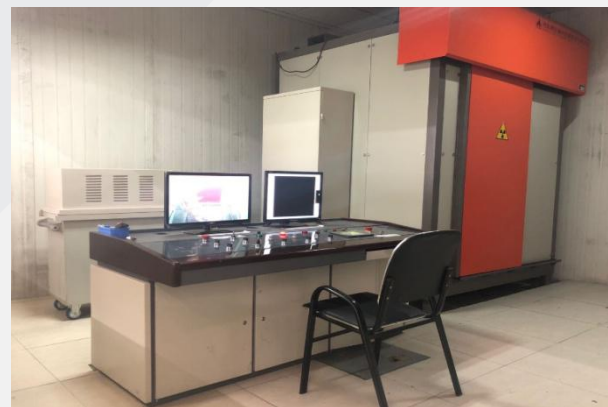

X-Ray探伤机  
X-Ray detector

# 机加工检测能力

Inspection capability



完善的实验室检测、试验能力 Perfect inspection device, excellent inspection ability

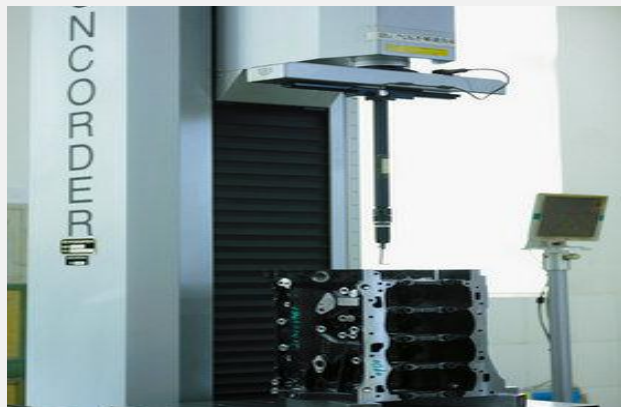

日本进口柱度仪  
Japan imported cylindrical instrument



三坐标仪  
CMM



德国Mahr粗糙度轮廓仪  
German Mahr roughness profiler



工业视频内窥镜  
Industrial video endoscope



手持式光谱分析仪  
Handheld spectrum analyzer

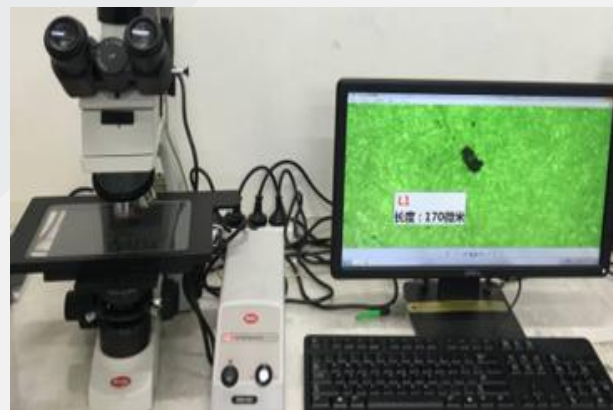

颗粒分析仪  
Particle analyzer





# 合作双赢，共享未来！

Win-win cooperation, sharing the future!



公司网址：[www.zhdl.com](http://www.zhdl.com)



联系方式：400-012-9020

